

SUGGESTED HOLE SIZES FOR DIE CASTING

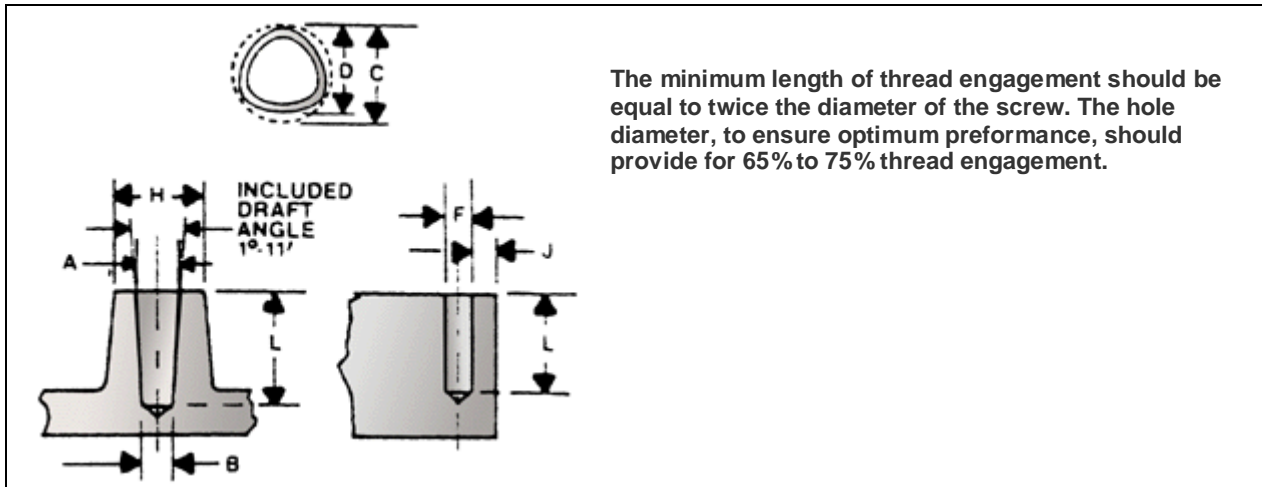

Screw Size	Hole Diameter as Cast Std. Taper				F Hole Dia. as Drilled	L Length of Thread Engagement	H Boss Dia. Max.	J Distance to Edge for no Measurable Distortion - Min.
	A - Top		B - Bottom					
	Max.	Min.	Max.	Min.				
M2 x 0.40	1.91	1.83	1.81	1.73	1.81	4.00	3.32	1.04
2-56	.081	.078	.077	.074	.077	.172	.197	.046
M2.5x0.45	2.39	2.31	2.28	2.20	2.28	5.00	4.15	0.55
3-48	.093	.090	.088	.085	.088	.198	.208	.054
M3x0.5	2.90	2.82	2.76	2.68	2.76	6.00	4.98	0.61
5-40	.118	.115	.112	.109	.112	.250	.232	.065
M3.5x0.6	3.31	3.23	3.21	3.13	3.21	7.00	5.81	0.74
6-32	.128	.125	.122	.119	.122	.276	.242	.081
M4x0.7	3.82	3.74	3.64	3.56	3.64	8.0	6.64	0.86
8-32	.155	.152	.148	.145	.148	.328	.272	.081
M4.5x0.75	4.31	4.23	4.11	4.03	4.11	9.00	7.47	0.92
10-24	.177	.174	.168	.165	.168	.380	.315	.108
10-32	.182	.179	.174	.171	.174	.380	.315	.081
M5x0.8	4.8	4.72	4.58	4.50	4.58	10.00	8.30	.098
12-24	.203	.200	.194	.191	.194	.432	.359	.108
M6x1.0	5.75	5.66	5.48	5.40	5.48	12.00	9.96	1.23
M6.3x1.0	6.05	5.97	5.78	5.70	5.78	13.00	10.46	1.23
1/4-20	.235	.232	.224	.221	.224	.500	.415	.130
M7x1.0	6.78	6.70	6.48	6.40	6.48	14.00	11.62	1.23
5/16-18	.267	.294	.284	.281	.284	.625	.519	.144
M8x1.25	7.69	7.61	7.32	7.27	7.35	16.00	13.28	1.53
3/8-16	.359	.356	.343	.340	.343	.750	.623	.162
M10x1.5	9.64	9.56	9.22	9.14	9.22	20.00	16.60	1.84
7/16-14	.419	.416	.400	.397	.400	.875	.726	.186
M12x1.75	11.59	11.51	11.09	11.01	11.09	24.00	19.92	2.15

1/2-13	.481	.478	.460	.457	.460	1.00	.830	.200
--------	------	------	------	------	------	------	------	------