

Description: **RADIUSED DOG (PILOT) POINT**

Thread type: **INCH - [UNC] COARSE**

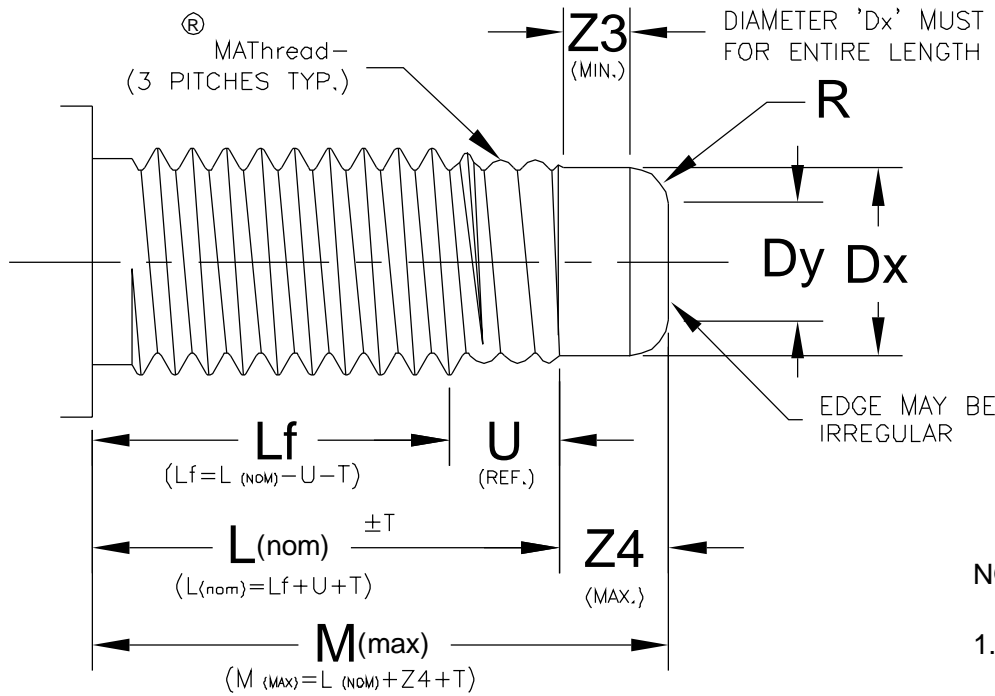

NOTE:

- 'M' IS THE MAXIMUM OVERALL LENGTH. DO NOT LIST A MINIMUM.
- 'Lf' = REQUIRED MINIMUM FULL THREAD LENGTH. 'Lf' DIMENSION MUST BE ON FINISHED PART DRAWING.
- POINT RADIUS (R) MUST BE TANGENT TO DOG POINT.
- DIMENSION 'L' IS MEASURED TO THE LEAD THREAD WHERE THE THREAD PROFILE FIRST EXCEEDS .20 x PITCH IN HEIGHT (MEASURED FROM THE THREAD ROOT)
- DO NOT CHANGE DIMENSIONS 'Z3' OR 'Dx' WITHOUT CONSULTING WITH MATHread Inc.
- T = .010

THREAD SIZE & PITCH	MAT LENGTH (REF.) U	DOG POINT DIAMETER Dx	TIP DIA. (MAX.) Dy	POINT RADIUS (MIN.) R	STR. LENG. (MIN.) Z3	POINT LENG. (MAX.) Z4
1/4 - 20	.150	.189 / .193	0.154	0.02	0.065	.100
5/16 - 18	.167	.245 / .249	0.190	0.03	0.085	.130
3/8 - 16	.188	.301 / .305	0.205	0.05	0.115	.180
7/16 - 14	.214	.352 / .356	0.220	0.07	0.135	.220
1/2 - 13	.231	.409 / .413	0.260	0.08	0.165	.260
9/16 - 12	.250	.464 / .468	0.275	0.10	0.180	.295
5/8 - 11	.273	.519 / .523	0.290	0.12	0.215	.350

DIMENSIONS ARE IN INCHES (in)

THIS DOCUMENT AND THE INFORMATION CONTAINED HEREIN IS THE PROPERTY OF MATHREAD, INC., WHITMORE LAKE, MI, USA. THE PRODUCTS DESCRIBED HERE ARE COVERED UNDER ONE OR MORE U.S. AND INTERNATIONAL PATENTS, INCLUDING BUT NOT LIMITED TO: 5,730,566; 5,791,849; 5,836,731; 5,997,231; 6,062,786; 6,162,001; 6,561,741 B2. THE PRODUCTS DESCRIBED HERE MAY NOT BE MANUFACTURED OR MARKETED, EXCEPT UNDER LICENSE FROM MATHREAD INC.. USE OF THE INFORMATION CONTAINED ON THIS PAGE IN MANUFACTURE AND/OR SALE OF THE PRODUCTS DESCRIBED HERE IS PROHIBITED WITHOUT THE EXPRESSED WRITTEN PERMISSION OF MATHREAD INC.